

ENGINE

Model	Isuzu 4HK1X, Tier III certified
Type	4-stroke, turbocharged
Cylinders	4
Bore/Stroke	4.53 in x 4.92 in (115 x 125 mm)
Displacement	317 in ³ (5.2 L)
Fuel injection	Direct
Fule injection pump	Electronic
Fuel	Diesel
Cooling	Liquid
Horsepower per SAE J1349	
Net	157 hp (117 kW) @ 1800 rpm
Maximum torque @ 1500 rpm	
Net	463 lb-ft (628 N-m)

BOOM/ARM

Boom

Length	18 ft 8 in (5.7 m)
Boom w/arm cylinder & plumbing	4,171 lb (1892 kg)
Hoist cylinders (2)	373 lb (169 kg) ea
Total weight	4,916 lb (2230 kg)

9 ft 8 in Arm (2.94 m)

Bare arm	1,537 lb (697 kg)
Bucket cylinder linkage & plumbing	1,175 lb (533 kg)
Total arm weight	2,712 lb (1230 kg)

7 ft 10 in Arm (2.4 m)

Bare arm	1,477 lb (670 kg)
Bucket cylinder linkage & plumbing	1,175 lb (533 kg)
Total arm weight	2,652 lb (1203 kg)

UNDERCARRIAGE

Number of top rollers	
Top, each track	2
Bottom, each track	8
Number of shoes	
Triple grouser – each track	49
Link pitch	7.48 in (190 mm)
Gradability	70%

HYDRAULICS

Pumps (2)	Variable displacement axial piston design
Capacity –	
Maximum	2 x 55.7 gpm (211 L/min)
System relief pressure –	
Standard	4,975 psi (34.3 MPa)
Power Boost	5,337 psi (36.8 MPa)
Control valves –	
4-spool section for right track travel, bucket, boom and arm acceleration	
5-spool section for left track travel, auxiliary, swing, boom acceleration and arm	
Boom and arm anti-drift valves	
Pilot control hydraulic system –	
Pump (1)	Gear design
Maximum capacity	4.8 gpm (18.0 L/min)
Relief pressure	566 psi (3.9 MPa)
Swing –	
Motor (1)	Fixed displacement axial piston design
Speed	0-11.5 rpm
Brake	Spring-applied hydraulically released with dual cushion relief
Travel –	
Motor (2)	Two-speed axial piston design
Final drive	Planetary gear reduction
Drawbar pull	42,534 lb (189.2 kN)
Travel Speeds –	
Auto shift high to low	
	Forward/Reverse
Low	2.1 mph (3.4 km/h)
High	3.5 mph (5.6 km/h)
Travel control valve –	Dual stage relief and counter-balance design

HYDRAULIC CYLINDERS

Boom cylinders (2) –	
Bore diameter	4.7 in (120 mm)
Rod diameter	3.3 in (85 mm)
Stroke	49.4 in (1255 mm)
Arm cylinder (1) –	
Bore diameter	5.5 in (140 mm)
Rod diameter	3.9 in (100 mm)
Stroke	57.5 in (1460 mm)
Bucket cylinder (1) –	
Bore diameter	4.7 in (120 mm)
Rod diameter	3.3 in (85 mm)
Stroke	39.8 in (1010 mm)

ELECTRICAL

Voltage	24 volts, negative ground
Alternator	50 amp
Batteries (2)	Low-maintenance 92 Ah (5 hr rate)

SERVICE CAPACITIES

Hydraulic tank	
Refill capacity	39 gal (147 L)
Total system	63 gal (240 L)
Final drive (per side)	4.8 qt (4.5 L)
Swing drive	5.3 qt (5.0 L)
Engine	
w/filter change	24.4 qt (23.1 L)
Fuel	108.3 gal (410 L)
Radiator	27.1 qt (25.6 L)

OPERATING WEIGHT

With 9 ft 8 in (2.94 m) arm, 31.5 in (800 mm) track shoes, 1,546 lb (701 kg) bucket, 165 lb (75 kg) operator, full fuel and standard equipment 47,400 lb (21 500 kg)

LIFT CAPACITIES

7 ft 10 in (2.40 m) Arm Lift capacities calculated using a 1,539 lb (698 kg) bucket, 9,083 lb (4120 kg) counterweight.

Load (Lift Point) Height	10 ft (3.05 m)		15 ft (4.57 m)		20 ft (6.1 m)		25 ft (7.62 m)		MAXIMUM REACH		
	END	SIDE	END	SIDE	END	SIDE	END	SIDE	@	END	SIDE
+25 ft (7.62 m)									23 ft 0 in (7.01 m)	7,750 lb* (3515 kg)*	7,750 lb* (3515 kg)*
+20 ft (6.1 m)					9,900 lb* (4491 kg)*	9,900 lb* (4491 kg)*			26 ft 8 in (8.12 m)	7,350 lb* (3334 kg)*	6,300 lb (2858 kg)
+15 ft (4.57 m)					10,950 lb* (4967 kg)*	10,300 lb (4672 kg)	10,350 lb* (4695 kg)*	6,850 lb (3107 kg)	28 ft 10 in (8.78 m)	7,250 lb* (3289 kg)*	5,350 lb (2427 kg)
+10 ft (3.05 m)	25,250 lb* (11 453 kg)*	25,250 lb* (11 453 kg)*	16,200 lb* (7348 kg)*	15,400 lb (6985 kg)	12,650 lb* (5738 kg)*	9,750 lb (4423 kg)	10,650 lb (4831 kg)	6,650 lb (3016 kg)	29 ft 10 in (9.09 m)	7,450 lb* (3379 kg)*	4,850 lb (2200 kg)
+5 ft (1.52 m)			20,600 lb* (9344 kg)*	14,150 lb (6418 kg)	14,500 lb* (6577 kg)*	9,150 lb (4150 kg)	10,350 lb (4695 kg)	6,400 lb (2903 kg)	29 ft 10 in (9.09 m)	7,750 lb (3515 kg)	4,700 lb (2132 kg)
Ground- line	17,500 lb* (7938 kg)*	17,500 lb* (7938 kg)*	22,550 lb* (10 229 kg)*	13,450 lb (6101 kg)	14,350 lb (6509 kg)	8,700 lb (3946 kg)	10,100 lb (4581 kg)	6,150 lb (2790 kg)	28 ft 10 in (8.46 m)	8,100 lb (3,674 kg)	4,950 lb (2245 kg)
-5 ft (-1.52 m)	26,050 lb* (11 816 kg)*	25,600 lb (11 612 kg)	22,800 lb* (10 342 kg)*	13,250 lb (6010 kg)	14,150 lb (6418 kg)	8,500 lb (3856 kg)	10,000 lb (4536 kg)	6,100 lb (2767 kg)	26 ft 8 in (8.12 m)	9,150 lb (4150 kg)	5,600 lb (2540 kg)
-10 ft (-3.05 m)	31,100 lb* (14 107 kg)*	27,200 lb (12 338 kg)	21,400 lb* (9707 kg)*	13,400 lb (6078 kg)	14,200 lb (6441 kg)	8,600 lb (3901 kg)			23 ft 1 in (7.03 m)	11,050 lb* (5012 kg)*	7,150 lb (3243 kg)
-15 ft (-4.57 m)	25,300 lb* (11 476 kg)*	25,300 lb* (11 476 kg)*	17,700 lb* (8029 kg)*	13,900 lb (6305 kg)							

9 ft 8 in (2.94 m) Arm Lift capacities calculated using a 1,435 lb (651 kg) bucket, 9,083 lb (4120 kg) counterweight.

Load (Lift Point) Height	10 ft (3.05 m)		15 ft (4.57 m)		20 ft (6.1 m)		25 ft (7.62 m)		MAXIMUM REACH		
	END	SIDE	END	SIDE	END	SIDE	END	SIDE	@	END	SIDE
+25 ft (7.62 m)									25 ft 2 in (7.6 m)	5,300 lb* (2404 kg)*	5,300 lb* (2404 kg)*
+20 ft (6.1 m)									28 ft 6 in (8.68 m)	5,050 lb* (2291 kg)*	5,050 lb* (2291 kg)*
+15 ft (4.57 m)					10,000 lb* (4536 kg)*	10,000 lb* (4536 kg)*	9,550 lb* (4332 kg)*	7,100 lb (3221 kg)	30 ft 5 in (9.27 m)	5,000 lb* (2268 kg)*	4,900 lb (2223 kg)
+10 ft (3.05 m)	22,000 lb* (9979 kg)*	22,000 lb* (9979 kg)*	14,750 lb* (6690 kg)*	14,750 lb* (6690 kg)*	11,850 lb* (5375 kg)*	10,000 lb (4536 kg)	10,450 lb* (4740 kg)*	6,850 lb (3107 kg)	31 ft 5 in (9.57 m)	5,150 lb* (2336 kg)*	4,500 lb (2041 kg)
+5 ft (1.52 m)	20,850 lb* (9457 kg)*	20,850 lb* (9457 kg)*	19,200 lb* (8709 kg)*	14,550 lb (6600 kg)	13,850 lb* (6282 kg)*	9,350 lb (4241 kg)	10,500 lb (4763 kg)	6,550 lb (2971 kg)	31 ft 5 in (9.57 m)	5,450 lb* (2472 kg)*	4,400 lb (1996 kg)
Ground- line	19,000 lb* (8618 kg)*	19,000 lb* (8618 kg)*	22,050 lb* (10 002 kg)*	13,650 lb (6192 kg)	14,500 lb (6577 kg)	8,850 lb (4014 kg)	10,200 lb (4627 kg)	6,250 lb (2835 kg)	30 ft 6 in (9.29 m)	6,050 lb* (2744 kg)*	4,550 lb (2064 kg)
-5 ft (-1.52 m)	25,200 lb* (11 431 kg)*	25,200 lb* (11 431 kg)*	22,700 lb* (10 297 kg)*	13,300 lb (6033 kg)	14,200 lb (6441 kg)	8,600 lb (3901 kg)	10,000 lb (4536 kg)	6,100 lb (2767 kg)	28 ft 6 in (8.68 m)	7,000 lb* (3175 kg)*	5,050 lb (2291 kg)
-10 ft (-3.05 m)	32,900 lb* (14 923 kg)*	26,900 lb (12 202 kg)	22,050 lb* (10 002 kg)*	13,350 lb (6055 kg)	14,150 lb (6418 kg)	8,550 lb (3878 kg)	10,050 lb (4559 kg)	6,150 lb (2790 kg)	25 ft 5 in (7.74 m)	8,750 lb* (3969 kg)*	6,200 lb (2812 kg)
-15 ft (-4.57 m)	28,250 lb* (12 814 kg)*	27,200 lb* (12 338 kg)*	19,450 lb* (8822 kg)*	13,700 lb (6214 kg)	13,800 lb* (6260 kg)*	8,800 lb (3992 kg)			19 ft 9 in (6.01 m)	8,450 lb* (3833 kg)*	8,450 lb* (3833 kg)*

NOTE: *Lift capacities do not exceed 75% of the minimum tipping load or 87% of the hydraulic lift capacity.
Capacities that are marked with an asterisk are hydraulic limited.

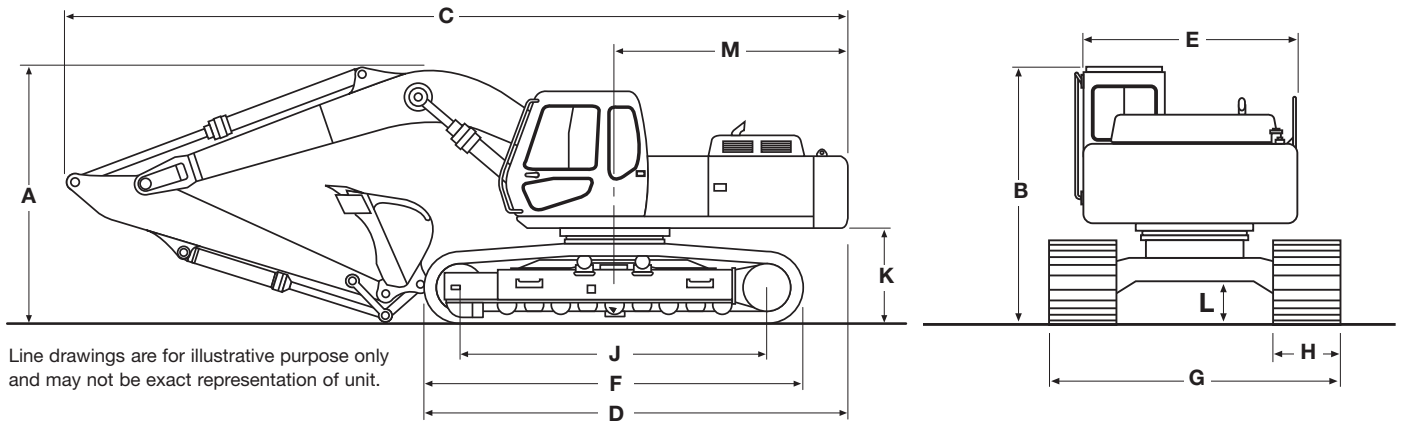

DIMENSIONS

	9 ft 8 in (2.94 m) Arm	7 ft 10 in (2.40 m) Arm
A. Overall height	9 ft 9 in (2.97 m)	10 ft 6 in (3.19 m)
B. Cab height	9 ft 8 in (2.94 m)	9 ft 8 in (2.94 m)
C. Overall length	30 ft 10 in (9.40 m)	31 ft 1 in (9.48 m)
D. w/o attachment	16 ft 3 in (4.96 m)	16 ft 3 in (4.96 m)
E. Width of upperstructure	9 ft 1 in (2.77 m)	9 ft 1 in (2.77 m)
F. Track overall length	14 ft 8 in (4.47 m)	14 ft 8 in (4.47 m)
G. Track overall width w/31.5 in (800 mm) shoes	10 ft 6 in (3.20 m)	10 ft 6 in (3.20 m)
H. Track shoe width	31.5 in (800 mm)	31.5 in (800 mm)
J. Center to center (idler to sprocket)	12 ft 0 in (3.66 m)	12 ft 0 in (3.66 m)
K. Upperstructure ground clearance	3 ft 5 in (1.04 m)	3 ft 5 in (1.04 m)
L. Minimum ground clearance	18 in (460 mm)	18 in (460 mm)
M. Tail swing radius	9 ft 0 in (2.75 m)	9 ft 0 in (2.75 m)
Working weight*	47,400 lb (21 500 kg)	47,340 lb (21 473 kg)
Ground pressure	5.2 psi (36 kPa)	5.2 psi (36 kPa)

*With 31.5 in (800 mm) track shoe, 1,546 lb (701 kg) bucket, 165 lb (75 kg) operator, full fuel and standard equipment.

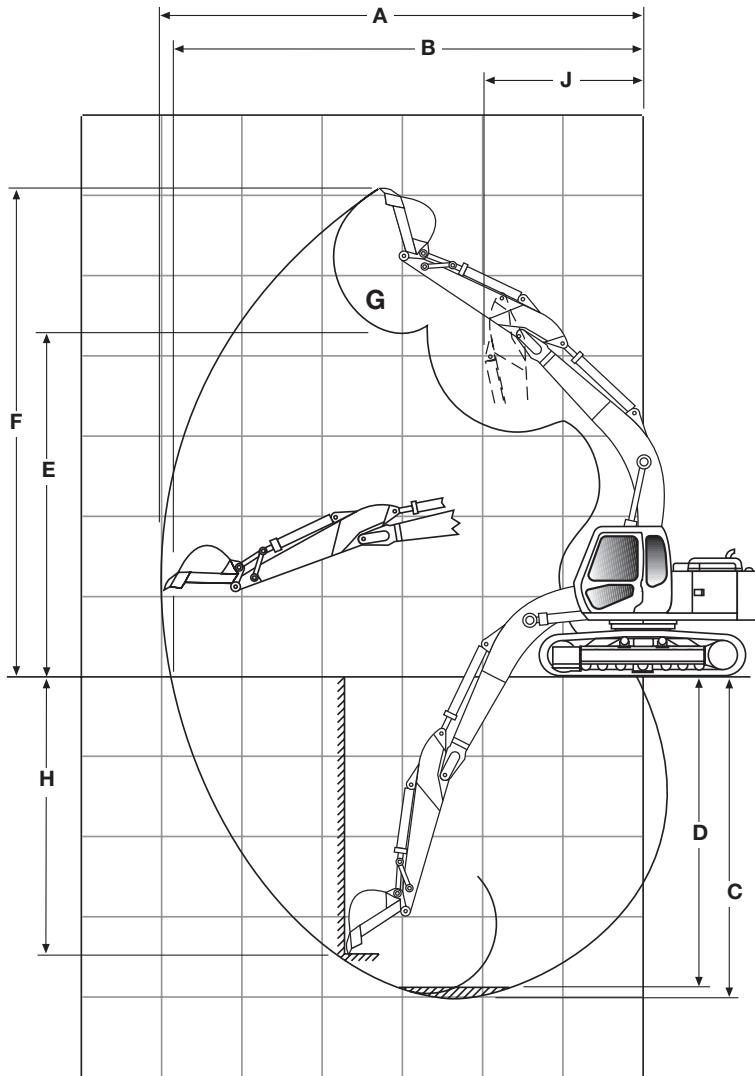

PERFORMANCE SPECS

	9 ft 8 in (2.94 m) Arm	7 ft 10 in (2.40 m) Arm
A. Maximum dig radius	32 ft 6 in (9.90 m)	30 ft 11 in (9.42 m)
B. Dig radius at groundline	31 ft 11 in (9.73 m)	30 ft 4 in (9.24 m)
C. Maximum dig depth	21 ft 10 in (6.65 m)	20 ft 0 in (6.11 m)
D. Dig depth - 8 ft 0 in (2.44 m) level bottom	21 ft 2 in (6.47 m)	19 ft 4 in (5.90 m)
E. Dump height	22 ft 4 in (6.81 m)	21 ft 7 in (6.59 m)
F. Overall reach height	31 ft 8 in (9.65 m)	30 ft 9 in (9.38 m)
G. Bucket rotation	177°	177°
H. Vertical straight wall dig depth	19 ft 7 in (5.96 m)	18 ft 1 in (5.50 m)
J. Minimum swing radius	12 ft 6 in (3.80 m)	11 ft 10 in (3.60 m)
Arm digging force		
Standard	23,155 lb (103 kN)	27,652 lb (123 kN)
Power Boost	24,728 lb (110 kN)	29,675 lb (132 kN)
Bucket digging force		
Standard	31,923 lb (142 kN)	31,923 lb (142 kN)
Power Boost	34,171 lb (152 kN)	34,171 lb (152 kN)

STANDARD EQUIPMENT

OPERATOR'S COMPARTMENT

Sliding front window - storable
LCD monitor display
Skylight
Cab with Isomount® system
Adjustable deluxe seat with 3 in (76 mm) retractable seat belt
Safety glass - all windows
Climate Control System
AM/FM Radio w/auto tuner
Windshield wiper w/washer
Anti-theft device
Dome light
12 volt power supply
24 volt power supply

ENGINE

Isuzu 4HK1X turbocharged diesel
Tier III certified
Warm up mode
Selectable one touch or auto accelerator/decelerator
Dial type throttle control
Emergency stop
Auto engine derate

OPTIONAL EQUIPMENT

UPPERSTRUCTURE

Arm: 9 ft 8 in or 7 ft 10 in
(2.94 m or 2.40 m)
FOPS guard level 2
Front screen
Front grill
Sun visor
Rain deflector
See through skylight

ELECTRICAL

Batteries (2)
Electronic Systems Monitor
Boom worklight
Turntable worklight

HYDRAULICS

ISO pattern pilot controls
Work mode selector: SP, H & Auto
Auto Power Boost
2 Variable flow piston pumps
Auxiliary attachment mode
Auto pump destroke
Auxiliary hydraulic valve
Arm and boom anti-drift valve
Attachment cushion control for boom and arm
100% return oil filtration

HYDRAULICS

Auxiliary hydraulics
Single acting, one pump
Double acting, single or dual pump
(includes heavy-duty bucket linkage)
Double acting general purpose for use with thumb kit
Control pattern selector valve

UNDERCARRIAGE

Shoes: 31.5 in (800 mm) 3-bar, 49 per side
Track length: 14 ft 8 in (4.47 m)
Track gauge: 7 ft 10 in (2.39 m)
Sealed and lubed track

TRACK DRIVE

2-speed hydrostatic travel
Disc-type parking brakes

UPPERSTRUCTURE

Boom: 18 ft 8 in (5.7 m) one piece
Hammer adaptable
Swing brake

OTHER

Counterweight: 9,083 lb (4120 kg)
Single key lockup

OTHER

Air suspension seat
24 in. (600 mm) track shoes
Load holding control devices
Cylinder mounted
Esco* hydraulic coupler

BUCKETS

Application	Width	SAE Heaped Capacity
General purpose	24 in thru 48 in (0.61 m thru 1.22 m)	0.62 yd ³ thru 1.50 yd ³ (0.47 m ³ thru 1.15 m ³)
Heavy-duty	24 in thru 48 in (0.61 m thru 1.22 m)	0.62 yd ³ thru 1.50 yd ³ (0.47 m ³ thru 1.15 m ³)
Extreme-duty	24 in thru 42 in (0.61 m thru 1.07 m)	0.50 yd ³ thru 1.125 yd ³ (0.38 m ³ thru 0.86 m ³)
Ditch	60 in or 66 in (1.52 m or 1.68 m)	1.00 yd ³ or 1.12 yd ³ (0.76 m ³ or 0.86 m ³)

This page intentionally left blank.

NOTE: All specifications are stated in accordance with SAE Standards or Recommended Practices, where applicable.

NOTE: All engines meet current EPA emissions requirements.

IMPORTANT: Case Construction Equipment Inc. reserves the right to change these specifications without notice and without incurring any obligation relating to such change. Case Construction Equipment Inc. does not warrant the safety or reliability of attachments from other manufacturers.

Case is a registered trademark of CNH America LLC. Any trademarks referred to herein, in association with goods and/or services of companies other than CNH America LLC, are the property of those respective companies.



www.casece.com

